

MODEL 7353
REGULATED DC POWER SUPPLY
OPERATION MANUAL

印刷表紙使用のこと

KIKUSUI ELECTRONICS CORP.

Power Requirements of this Product

Power requirements of this product have been changed and the relevant sections of the Operation Manual should be revised accordingly.

(Revision should be applied to items indicated by a check mark)

Input voltage

The input voltage of this product is _____ VAC,
and the voltage range is _____ to _____ VAC. Use the product within this range only.

Input fuse

The rating of this product's input fuse is _____ A, _____ VAC, and _____.

WARNING

- To avoid electrical shock, always disconnect the AC power cable or turn off the switch on the switchboard before attempting to check or replace the fuse.
- Use a fuse element having a shape, rating, and characteristics suitable for this product. The use of a fuse with a different rating or one that short circuits the fuse holder may result in fire, electric shock, or irreparable damage.

AC power cable

The product is provided with AC power cables described below. If the cable has no power plug, attach a power plug or crimp-style terminals to the cable in accordance with the wire colors specified in the drawing.

WARNING

- The attachment of a power plug or crimp-style terminals must be carried out by qualified personnel.



1. Outline

Model 7353 is a series type regulated d-c power supply employing transistors and the voltage range of 2 - 100V is varied continuously by 10-TURN potentiometer, resulting in utilization of max. output current of 0.3A.

It is a compact and light weight power supply provided with a voltmeter and an ammeter on the panel. The output current limit circuit which is positive in action is operated against overload and output shortcircuit accident and the limit current can be set continuously in the range of 10% - 100% of the max. rating.

At the same time, it serves also as constant current power supply.

This unit can be operated in series or parallel.

C O N T E N T S

1. Outline

2. Specifications

3. Explanation for Front panel

4. Use

4-1. Operation

4-1-1. Single operation

4-1-2. Series operation

4-1-3. Overload protection in series operation

4-1-4. Parallel operation

4-2. Cautions for installing place

4-3. Overshoot of output voltage

4-4. Voltage dropping of ammeter

4-5. Current limit circuit

5. Maintenance

2. Specifications

AC input

AC input source

V 50/60 Hz

Power consumption
(full load output 100V, 0.3A)

Approx. 75 VA

Ambient temperature

Max. 40°C

Dimensions

* 106W x 145H x 301Dmm

Largest part

111W x 158H x 345Dmm

Weight

Approx. 4.5 Kg

Accessories

Shorts bar 1

Operation Manual 1 copy

Test chart 1 copy

Output

Terminal

Color classification of
red, white and black

19 mm interval, equilateral
triangle arrangement

Polarity

Positive or negative po-
larity

Off ground voltage

Off ground voltage and

Max. +150V

Voltage

2 - 100V Variable con-
tinuously

Current

0.3A

Ripple

2mV r.m.s.

Regulation

20 mV against +10% fluctu-
ation of AC INPUT voltage.

**

30 mV against load fluctua-
tion of 2 - 100V, 0 - 0.3A

Current limiting (constant current 0.03A - 0.3A Continuously automatic Crossover type) variable

Voltmeter 110V Precision 2.5% of full scale

Ammeter 0.32A Precision 2.5% of full scale

Possible to operate in series and parallel.

* Possible to install 4 units in a row on the 19" and 500 mm standard rack.

** The voltage drop of the ammeter is compensated in circuit.

3. Explanation for Panel

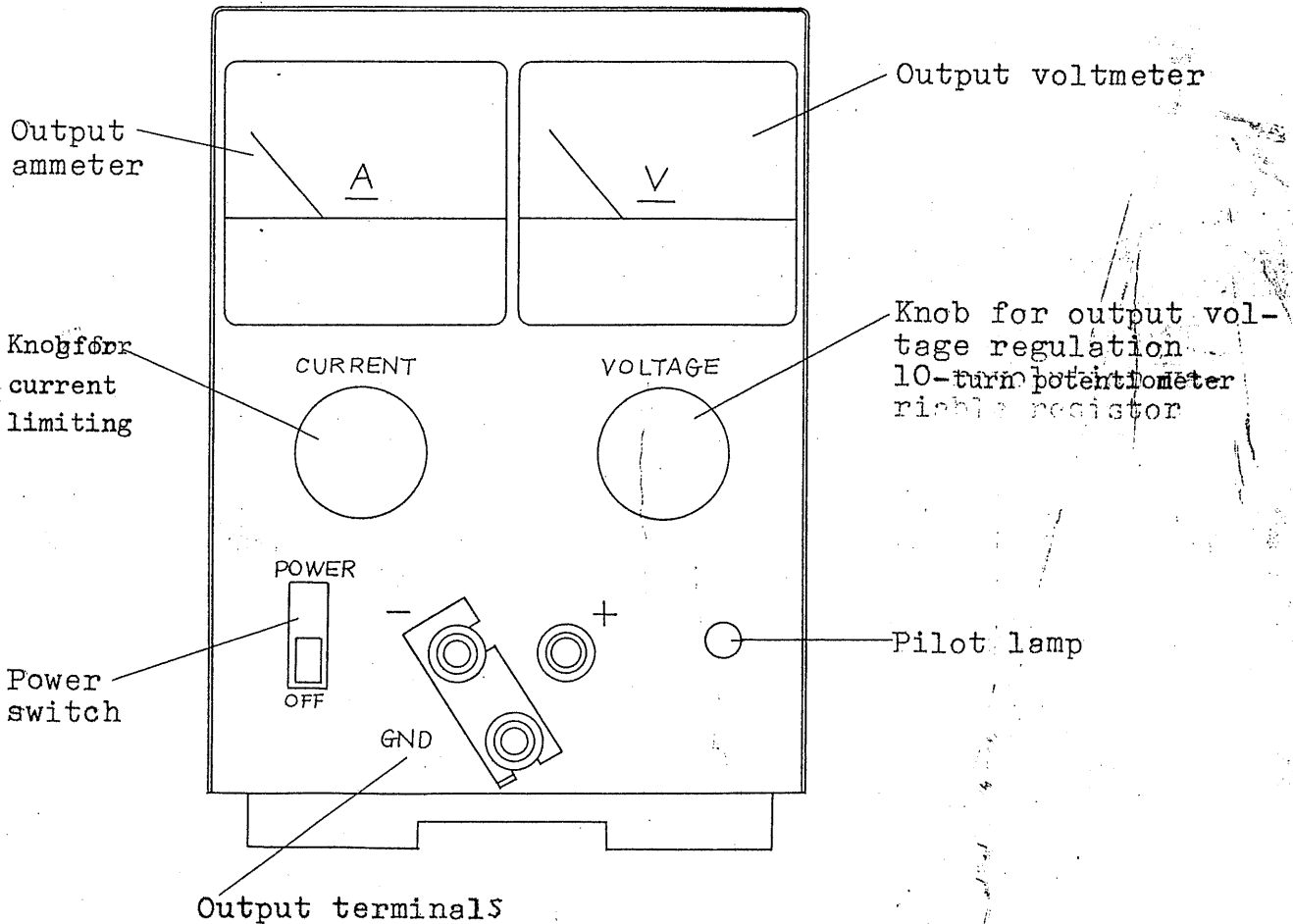

Usually, plus (+) or minus (-) terminal is connected with the GND terminal which is connected electrically with chassis/panel by means of the attached short bar and the unit is used.

It can be operated by applying d-c bias. (Refer to Item OFF GROUND VOLTAGE.)

Knob for Current Limiting

The output current can be limited in the range of 10% - 100% of the maximum rating. Within the said range, it can be utilized as constant current power supply.

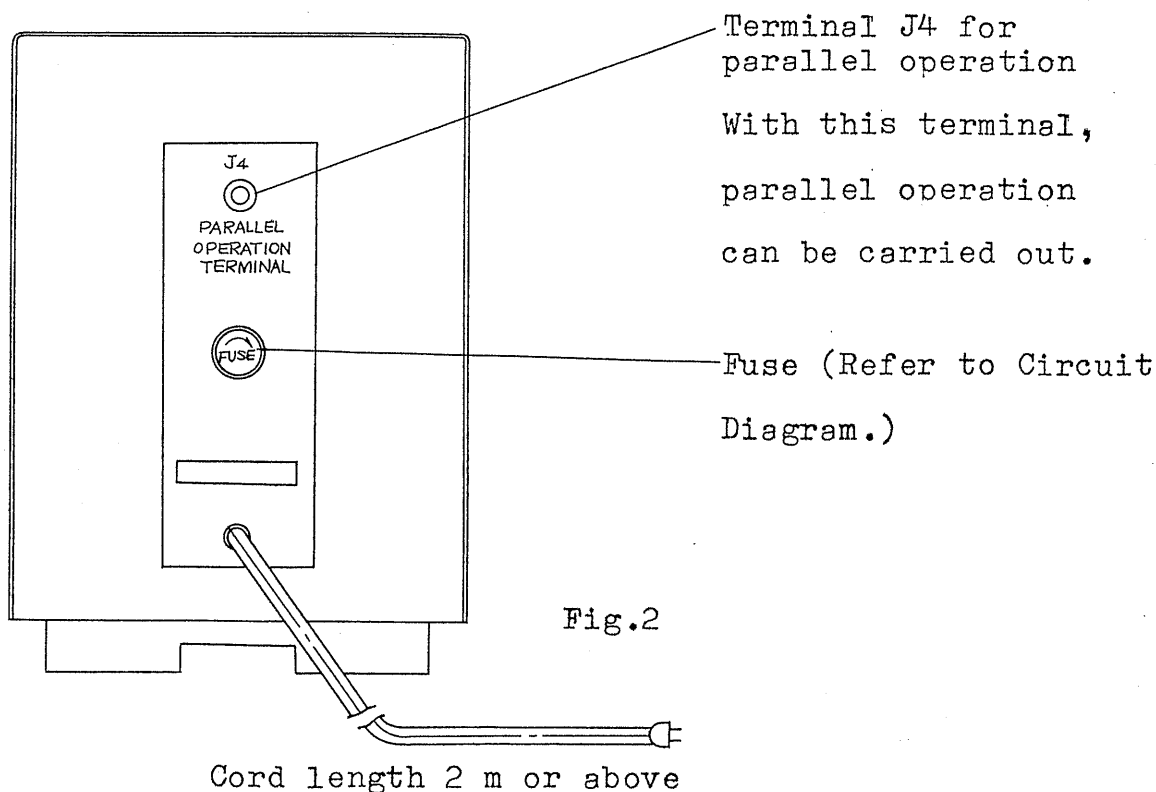

Fig.2

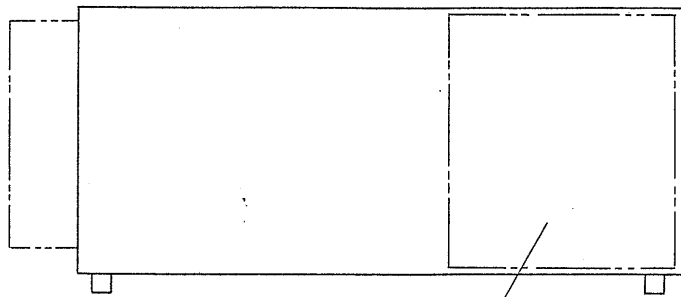

Fig.3

Heat sink

When used in the vicinity of low voltage and max. current, pay attention to ventilation of the heat sink.

4-1. Operation

4-1-1. ~~Single Operation~~ Single Operation

When this unit is used ~~single, use it as it is.~~ as it is.

4-1-2. Series Operation

When more than 2 units are connected in series, voltage higher than that for one unit can be utilized. In this case, any terminal should not exceed the rated off ground voltage against the panel/chassis.

In series operation of two units, voltage which is two times as big as the rated voltage and the current equal to that of rated portion for one unit can be utilized.

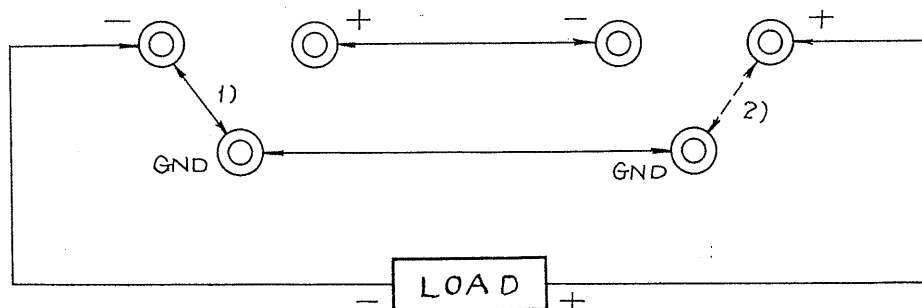

Fig.4

Wiring is provided as follows for connection of GND terminal.

- 1) In the case of minus grounding (connection shown with the bold line of Fig.4)
- 2) In the case of plus grounding (connection shown with the dotted line of Fig.4)

Avoid grounding the respective GND terminals to different polarity.

4-1-3. Overload protection in series operation

When an overload phenomenon develops upon series connection of more than two units of regulated power supplies, output voltage of the other side will be applied to the machine of which protective circuit is operated earlier in the opposite direction, resulting in breaking the series element of the former the former.

In order to prevent such, diode is connected between output terminals of the respective regulated power supplies as shown in Fig.5.

PATENT NO. 30882

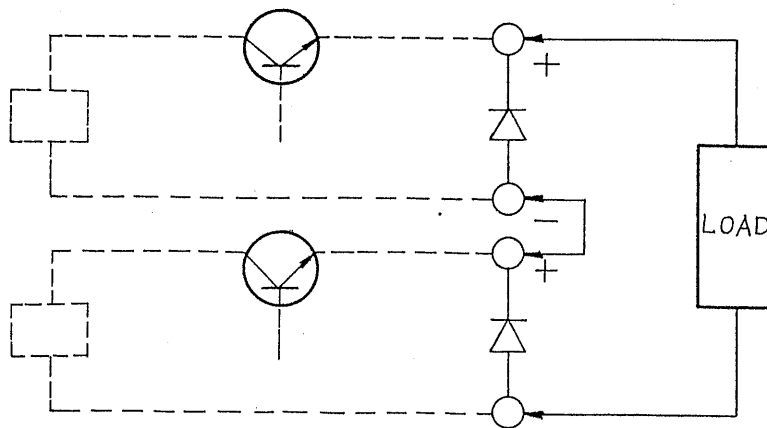

Fig.5

4-1-4. Parallel Operation (Master-slave)

For the purpose of utilization of the current twice by parallel operation of two units of the Set, operate as mentioned hereunder.

For providing the wiring, be sure to turn off the power switch.

In the case of parallel operation, one unit (master) and the other unit (slave) are operated respectively. The setting of output voltage and output current is done by the master unit.

- 1) Remove the lower cover of the slave unit and move the slide switch in the printed board from "MASTER" to "SLAVE".
- 2) Connect J4 of the (SLAVE) unit with the PARALLEL OPERATION TERMINAL J4 located at the back of the master unit.
- 3) Place the knob for CURRENT of (SLAVE) unit at current maximum position. That is, turn it fully clockwise.

Place VOLTAGE at max. position.

- 4) Fit the back cap

4) Fit the back cover of the (SLAVE) unit once again and turn on the power switch. Voltage and current can be varied freely by means of the (MASTER) unit. Even in this case, output current limit can be selected freely in the range of 10% - 100% of the value which is two times as big as the max. rated value.

As for the use of the short bar, minus or plus grounding must be provided both for (MASTER) unit and (SLAVE) unit.

Be sure to avoid grounding the different polarity both for (MASTER) unit and (SLAVE) unit.

(Refer to Fig.6.)

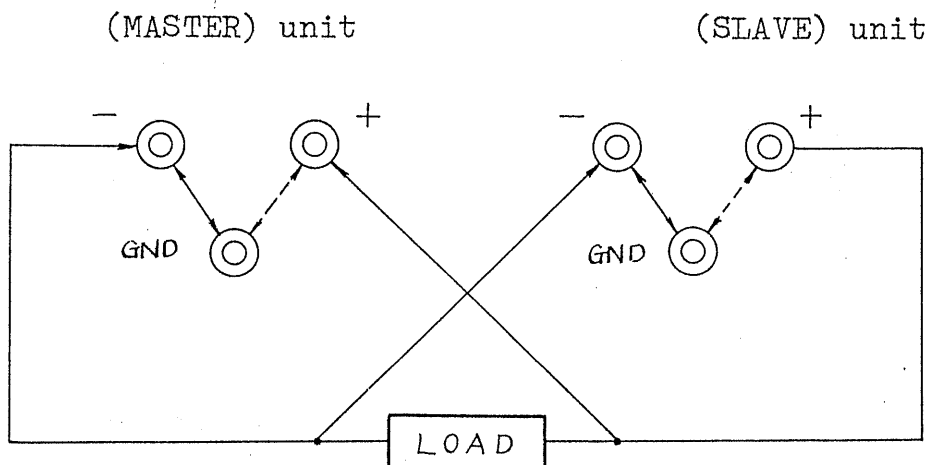

Fig.6.

The allowable max. number of units to be operated in parallel is 2.

In principle, parallel operation with other types of set can not be carried out.

Even if the power switch is turned on with the slide switch in the printed board at SLAVE, no output is produced. Pay attention to this point.

The usable range of two units in series or parallel operation is as shown in Fig.7.

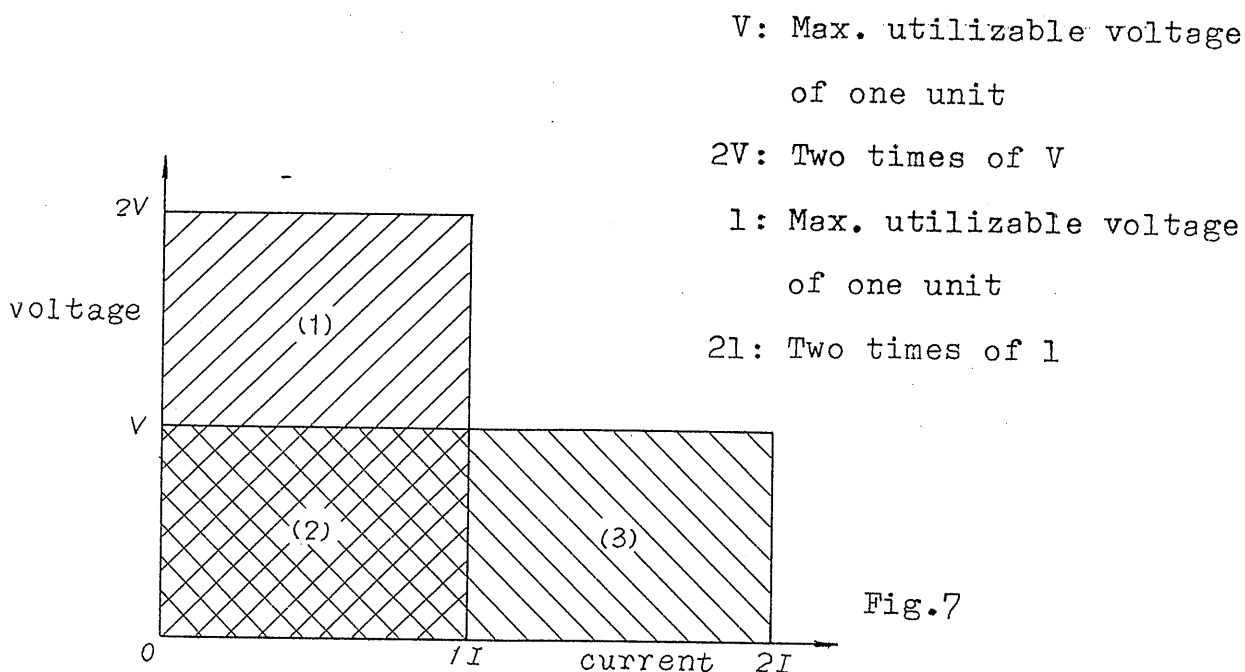

Fig.7

- Single operation Within the range of (2)
- Series operation Within the range of (1) + (2)
- Parallel operation Within the range of (2) + (3)
- Possible to use with the above.

4-2. Cautions for Installing Place

Be sure to avoid operating this unit in such a place where the ambient temperature exceeds 40°C so far as practicable.

If ventilation is hindered or the unit is subjected to radiation heat or exposed to direct sunlight, limit the continuous max. output current appropriately.

The range of AC Input voltage on which this unit is operated safely is 90% - 110% of the rated value.

4-3. Overshoot of output voltage

When the power switch is turned ON or OFF, no voltage higher than the set value will be produced between output terminals.

4-4. Voltage dropping of ammeter

The voltage dropping by output ammeter is ~~circuitscomp~~ ~~ensated~~ circuit.

4-5. Current limiting circuit

In order to prevent the series control element and output ammeter from being damaged instantaneously when a shortcircuiting phenomenon develops with the output terminals, this unit is provided with an electronic output current limit circuit which is positive in operation for the purpose of limiting the output current so that it does not run more than the rated value.

The output limit current can be varied continuously freely in the range of 10% - 100% of the max. rated value.

When the output current reaches the set value, this unit will be operated as constant current power supply.

When the output current returns lower than the set value, it will be operated automatically and continuously as constant voltage power supply once again.

(Refer to Fig.8)

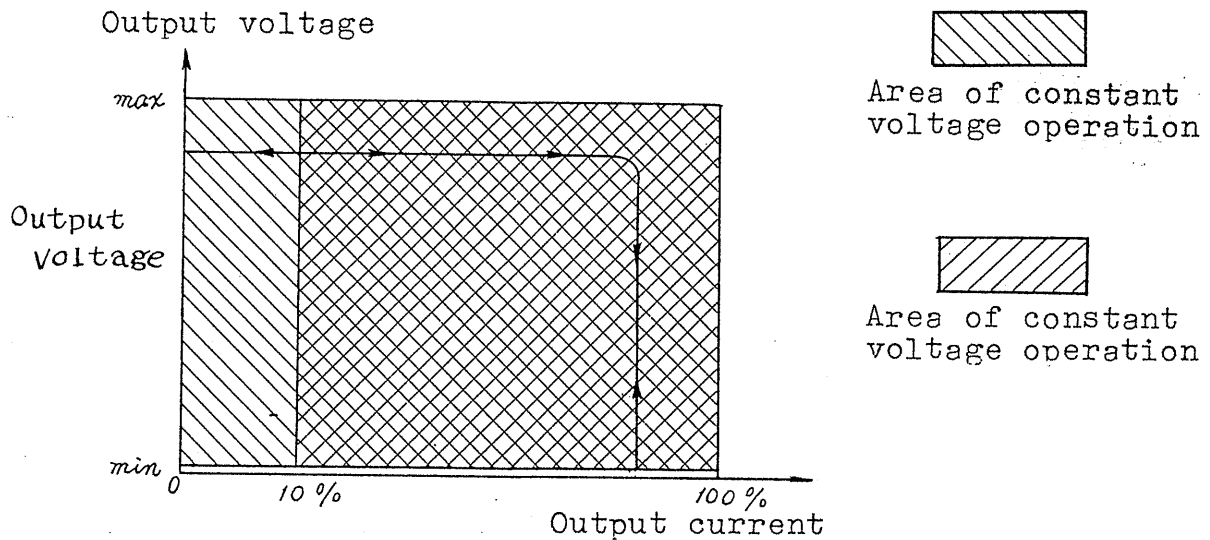

Fig.8

5. Maintenance

If parts are exchanged for new ones due to trouble or output voltage is incorrect, make the following adjustment.

5-1. OV ADJ

With the voltage adjusting knob on panel turned fully counterclockwise, adjust the semi-fixed resistor in the printed board (one with copper foil in the printed board, semi-fixed resistor in Fig.9 (1)).

In this case, adjust the output voltage within the range of $\pm 0.5V$.

5-2. Max. voltage ADJ

With the voltage adjusting knob on panel turned fully clockwise (when provided with fine adjustment knob, almost at central position), adjust the semi-fixed resistor in the printed board (semi-fixed resistor of Fig.9 (2) of the semi-fixed resistors with many parts in the printed board).

Repeat the aforementioned adjustment several times.

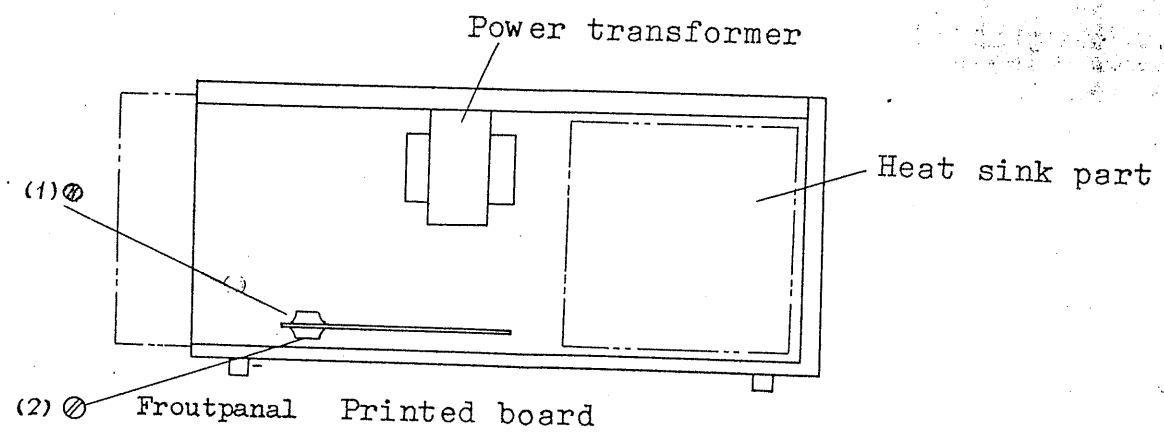

Fig.9